

NG 12

Aufnahmebohrung



moHy GmbH
Röntgenstraße 4 · 63755 Alzenau
Tel. +49 60 23 - 320 01 70
Fax +49 60 23 - 320 01 66
Email: moHy@moHy.info
www.moHy.info



C1220

2-Wege

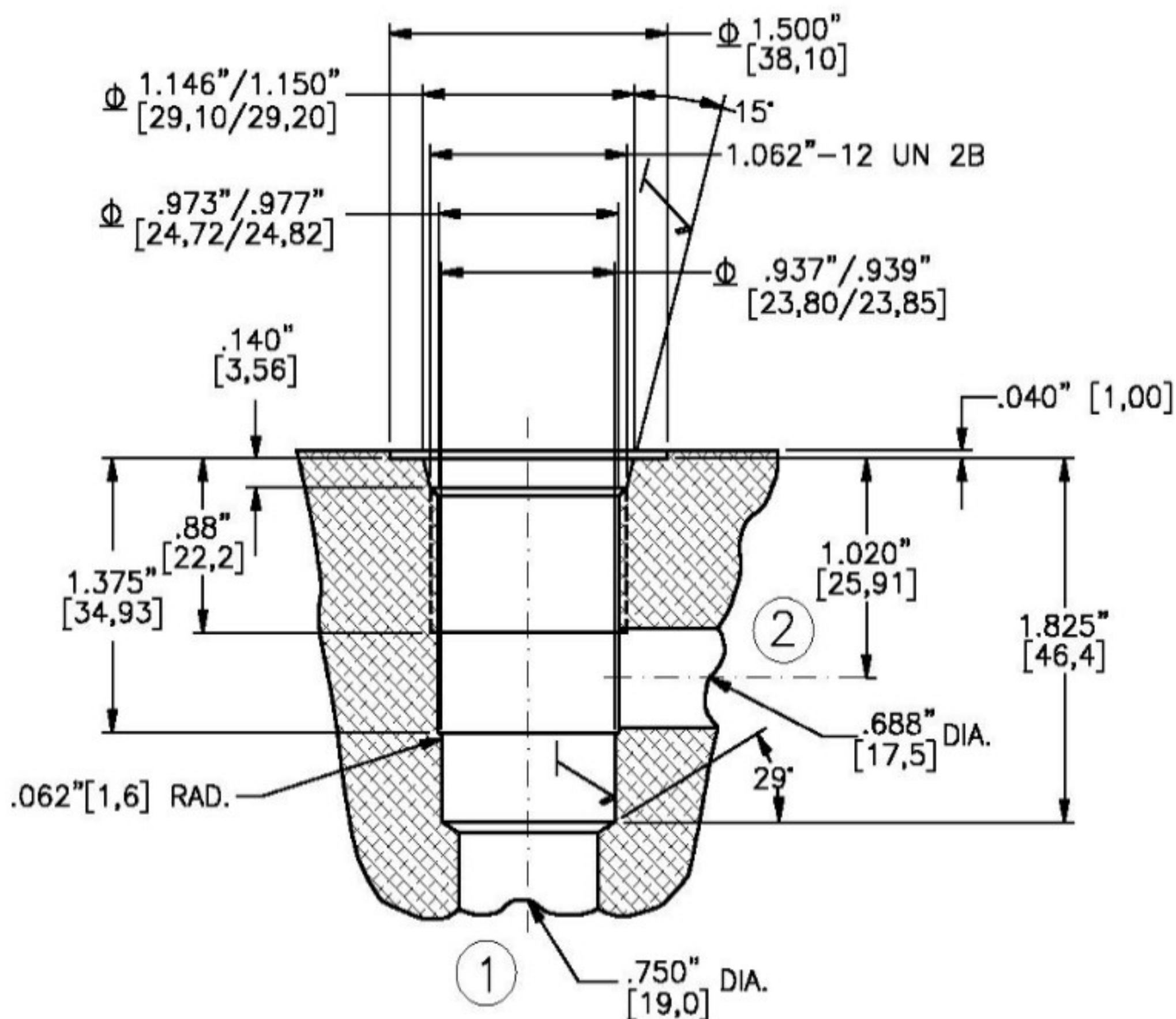

FINISH $\sqrt{\text{ }} = 1,15\text{m} \sqrt{\text{OR}} \quad 45\text{in} \sqrt{\text{ }} \quad \sqrt{\text{ }}$

Beachten: mm-Angaben in []

Cavity Roughing Tool



TOOL NO.: T1220-R-H
MATERIAL: High Speed Steel

Cavity Finishing Tool

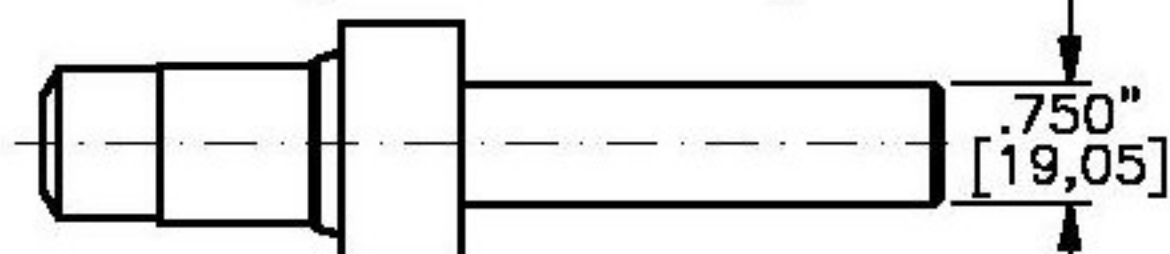

TOOL NO.: T1220-F-H
MATERIAL: High Speed Steel
TOOL NO.: T1220-F-C
MATERIAL: Tungsten Carbide Tipped