

NG 10

Aufnahmebohrung



moHy GmbH  
Röntgenstraße 4 · 63755 Alzenau  
Tel. +49 60 23 - 320 01 70  
Fax +49 60 23 - 320 01 66  
Email: moHy@moHy.info  
www.moHy.info



C1020

2-Wege

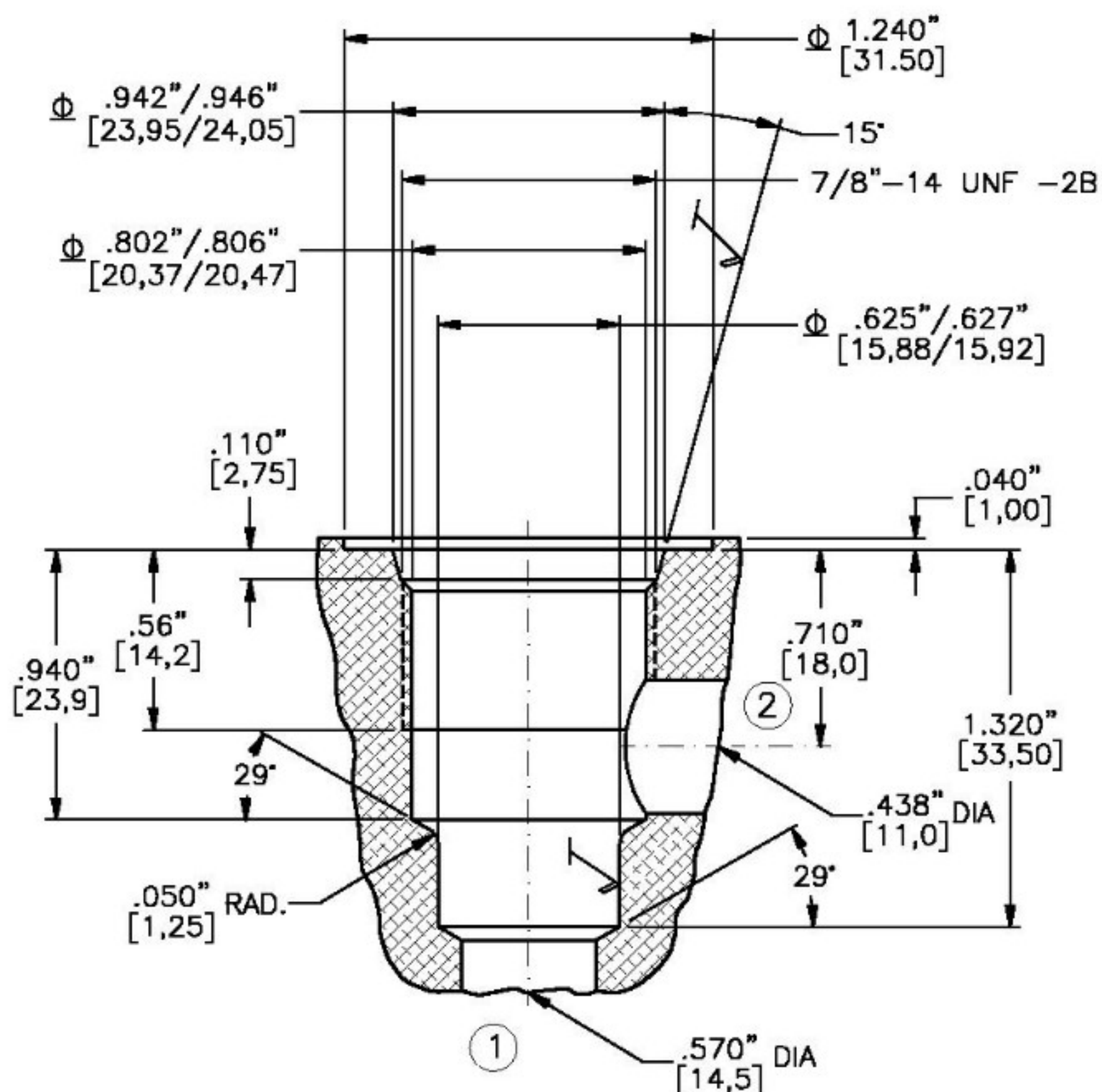

FINISH  $\sqrt{\text{ }} = 1,15\text{m}\sqrt{\text{ }} \text{ OR } 45\text{in}\sqrt{\text{ }}$

Beachten: mm-Angaben in [ ]

### Cavity Roughing Tool

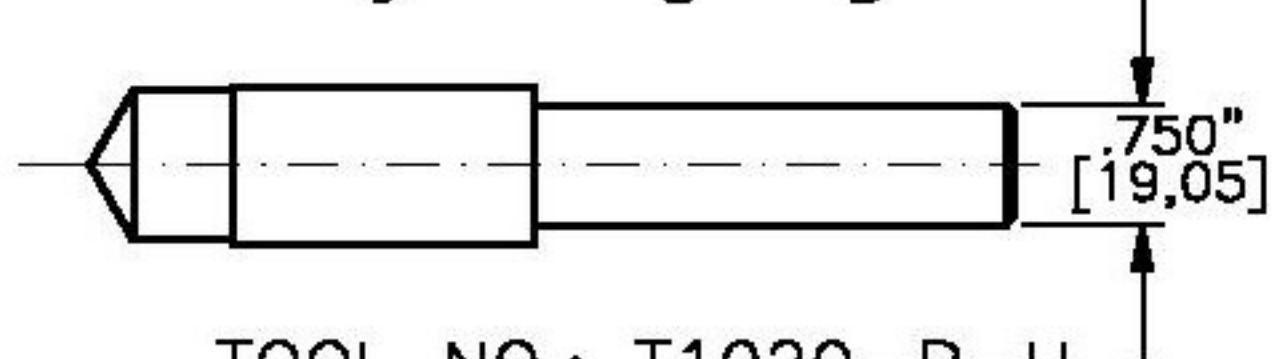

TOOL NO.: T1020-R-H  
MATERIAL: High Speed Steel

### Cavity Finishing Tool

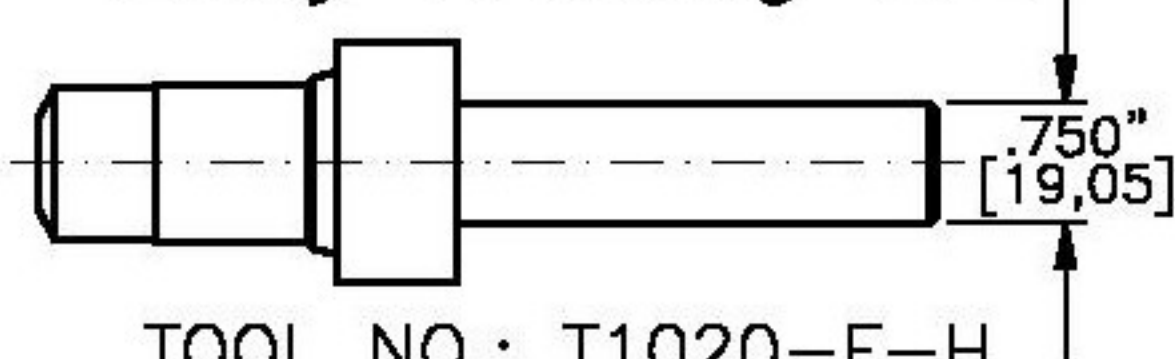

TOOL NO.: T1020-F-H  
MATERIAL: High Speed Steel  
TOOL NO.: T1020-F-C  
MATERIAL: Tungsten Carbide Tipped