

NG 08

Aufnahmebohrung



moHy GmbH
Röntgenstraße 4 · 63755 Alzenau
Tel. +49 60 23 - 320 01 70
Fax +49 60 23 - 320 01 66
Email: moHy@moHy.info
www.moHy.info



C0825

2,5-Wege

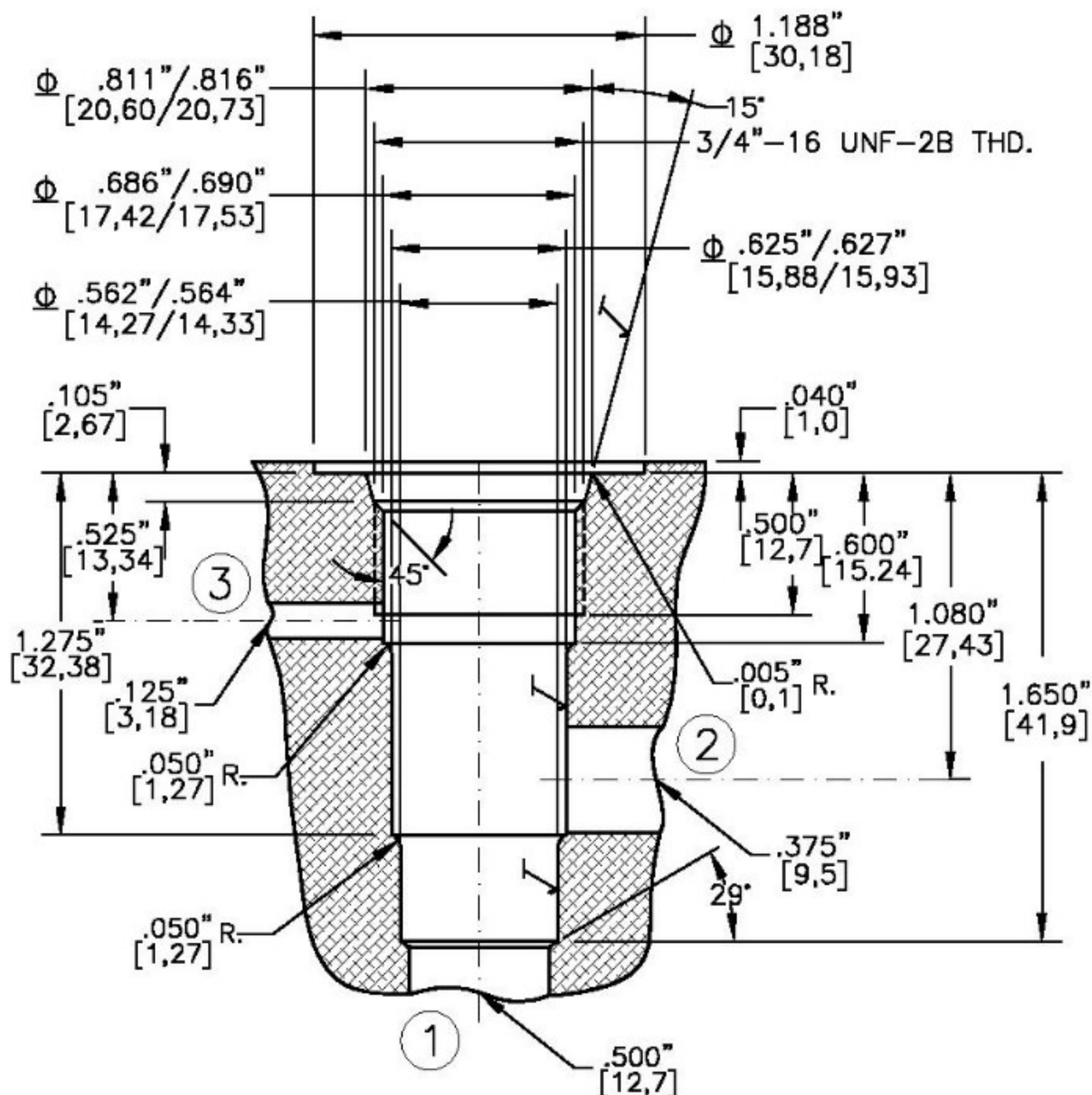

FINISH $\sqrt{\text{ }} = 1,15\text{m}$ $\sqrt{\text{OR}}$ 45in $\sqrt{\text{ }}$

Beachten: mm-Angaben in []

Cavity Roughing Tool

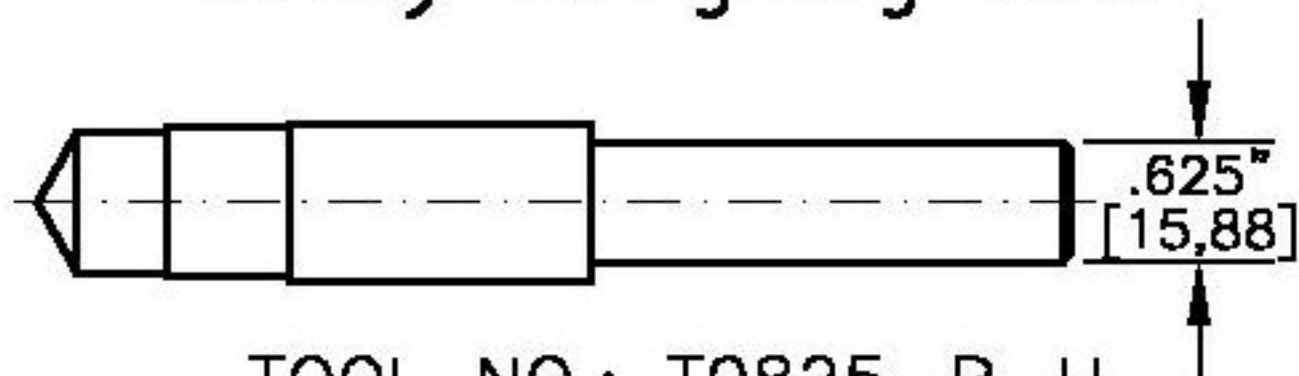

TOOL NO.: T0825-R-H
MATERIAL: High Speed Steel

Cavity Finishing Tool

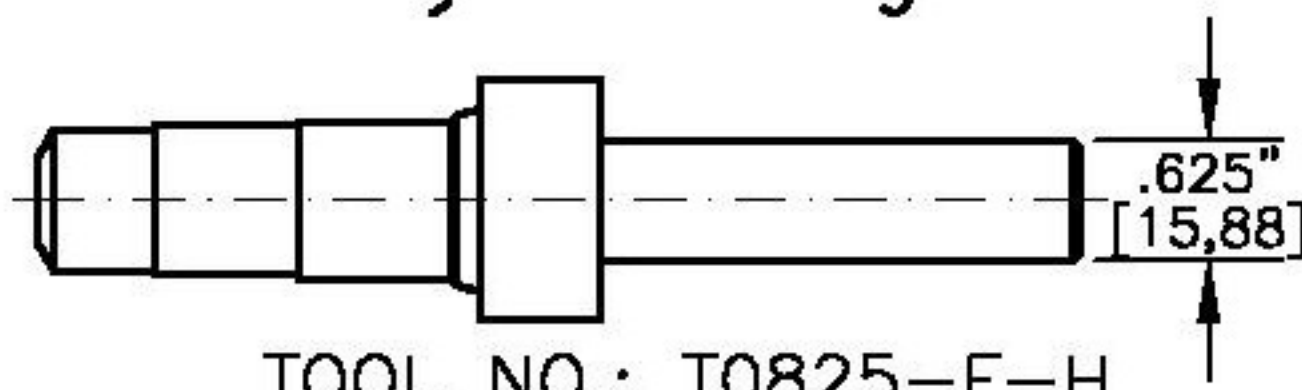

TOOL NO.: T0825-F-H
MATERIAL: High Speed Steel
TOOL NO.: T0825-F-C
MATERIAL: Tungsten Carbide Tipped